

## HT Series Water-Proof Distribution Box

**CHANA**<sup>®</sup>



### Description

- Rated voltage/rated frequency: 690V/50Hz
- Material: Shell-PC  
Body-ABS
- Color: RAL7035
- Tested and approved to EN 60947-1
- Protection degree: IP55
- Din rail connection according to EN 50022
- Supplied with removable earth bar

### Specification

Model	Way No.	Dimension(mm)		
		W	H	D
HT-5	5	120	160	90
HT-8	8	200	155	93
HT-12	12	253	197	108
HT-15	15	310	200	108
HT-18	18	365	198	108
HT-24	24	275	355	108

### Overall and Installation Dimension

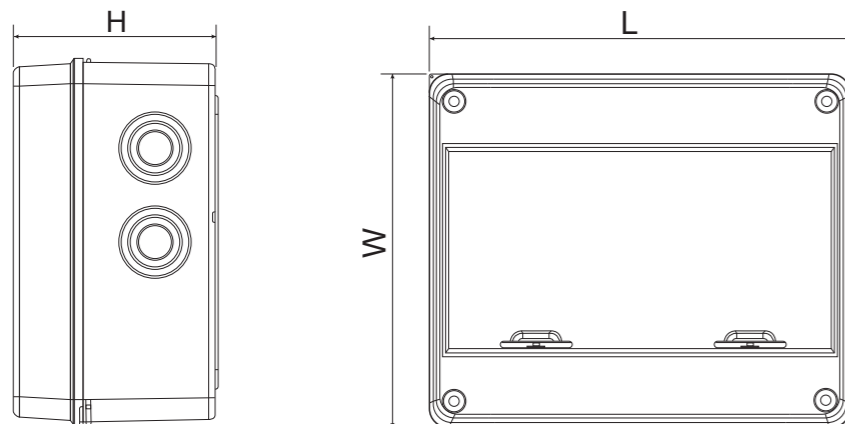

## HA Series Water-Proof Distribution Box

**CHANA**<sup>®</sup>



### Description

- Rated voltage/rated frequency: 690V/50Hz
- Material: Shell-PC  
Body-ABS
- Color: RAL7035
- Tested and approved to EN 60947-1
- Protection degree: IP55
- Din rail connection according to EN 50022
- Supplied with removable earth bar

### Specification

Model	Way No.	Dimension(mm)		
		W	H	D
HA-4	4	140	210	100
HA-8	8	215	210	100
HA-12	12	295	260	140
HA-18	18	410	285	140
HA-24	24	295	420	140

### Overall and Installation Dimension

